

MSD[®] IGNITION INSTALLATION INSTRUCTIONS

MSD Cap-A-Dapt PN 8445

Parts Included:

- | | |
|------------------------------|---------------------------------|
| 1 - Adapter Spacer, PN 8446 | 2 - 5/8" Phillips Screws |
| 1 - Cap, PN 8408 | 2 - 3/4" Phillips Screws |
| 1 - Rotor, PN 8423 | 2 - Belleville Washers |
| 1 - Wire Retainer | 2 - 3/4" Socket Head Cap Screws |
| 2 - 1.5" Self Tapping Screws | |

The MSD Cap-A-Dapt will fit most MSD Pro-Billet Distributors that were originally equipped with a GM Window/Points style distributor cap.

Note: Your spark plug wire terminals and boots may need to be changed to fit the Cap-A-Dapt.

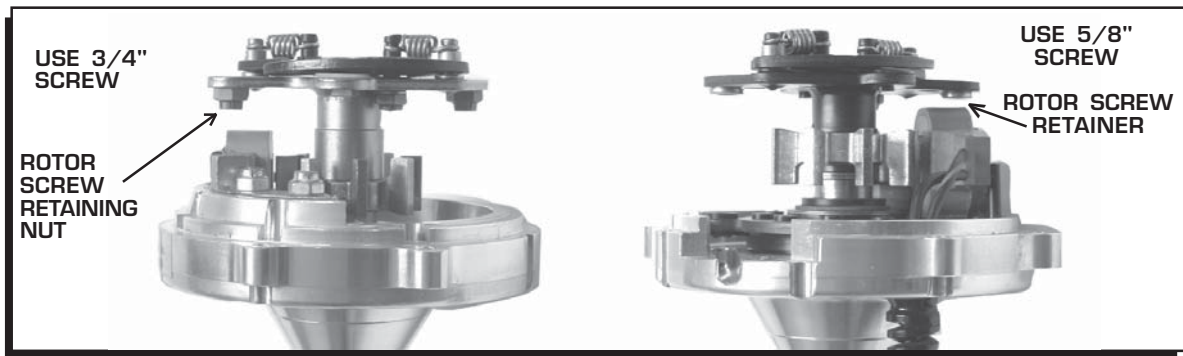

Figure 1 Determining Rotor Screw Length.

1. Note which spark plug wire connects to which terminal to ensure correct routing when reassembling. Remove the existing distributor cap and rotor.
2. Before installing the Cap Spacer you need to determine which length rotor screw should be used. In some applications, the longer screw could make contact with the magnetic pickup and cause damage. Figure 1 shows the difference.
3. After selecting the correct rotor screws, fit the Adapter to the distributor base (Figure 2). The snap tangs will secure to the base of the distributor just like the original cap.

Note: You can also use the supplied screws to hold the spacer (Figure 3).

4. Install the new rotor. Note the position of the domed washers. The dome must face up.
5. Install the new distributor cap followed by the spark plug wires. Install the optional retainer with the supplied screws.

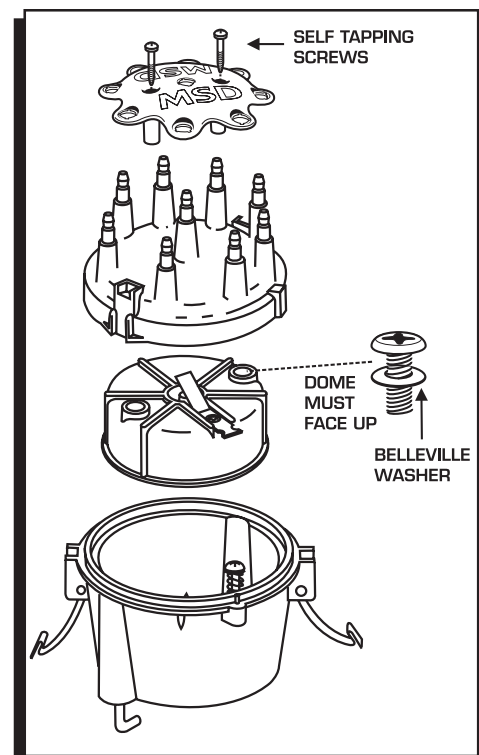

Figure 2 Installing the Cap-A-Dapt.

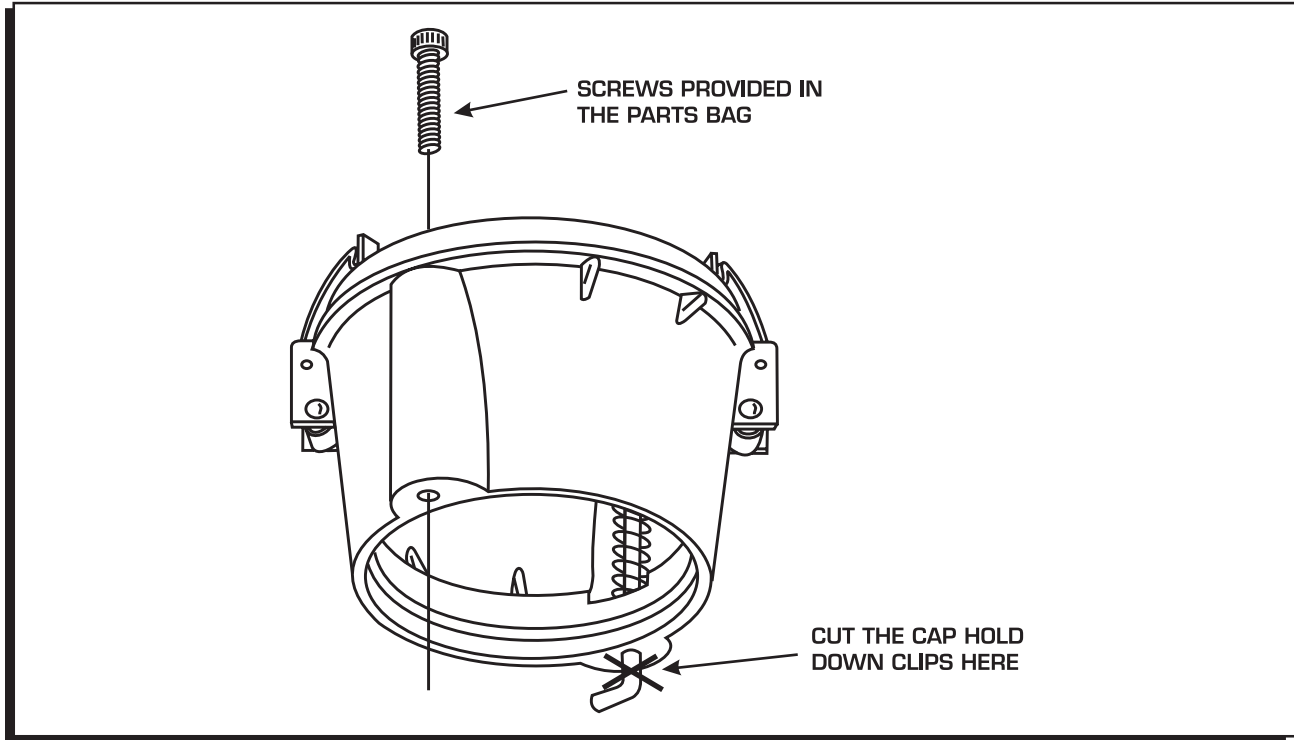

Figure 3 Using Bolts to Install the Adapter Spacer.

Service

In case of malfunction, this MSD component will be repaired free of charge according to the terms of the warranty. When returning MSD components for service, Proof of Purchase must be supplied for warranty verification. After the warranty period has expired, repair service is charged based on a minimum and maximum charge.

Send the unit prepaid with proof of purchase to the attention of: **Customer Service Department, Autotronic Controls Corporation, 12120 Esther Lama, Suite 114, El Paso, Texas 79936.**

When returning the unit for repair, leave all wires at the length in which you have them installed. Be sure to include a detailed account of any problems experienced, and what components and accessories are installed on the vehicle.

The repaired unit will be returned as soon as possible after receipt, COD for any charges. (Ground shipping is covered by warranty). All units are returned regular UPS unless otherwise noted. For more information, call the MSD Customer Service Line (915) 855-7123. MSD technicians are available from 8:00 a.m. to 5:00 p.m. Monday - Friday (Mountain Time).

Limited Warranty

Autotronic Controls Corporation warrants MSD Ignition products to be free from defects in material and workmanship under normal use and if properly installed for a period of one year from date of purchase. If found to be defective as mentioned above, it will be replaced or repaired if returned prepaid along with proof of date of purchase. This shall constitute the sole remedy of the purchaser and the sole liability of Autotronic Controls Corporation. To the extent permitted by law, the foregoing is exclusive and in lieu of all other warranties or representations whether expressed or implied, including any implied warranty of merchantability or fitness. In no event shall Autotronic Controls Corporation be liable for special or consequential damages.